

VLSI Design Verification and Testing

Delay Test

Mohammad Tehranipoor

Electrical and Computer Engineering
University of Connecticut

8 April 2008

1

Delay Test

- Delay test definition
- Circuit delays and event propagation
- *Path-delay tests*
 - *Non-robust test*
 - *Robust test*
 - Five-valued logic and test generation
- *Path-delay fault* (PDF) and other fault models
- Test application methods
 - Combinational, enhanced-scan and normal-scan
 - Variable-clock and rated-clock methods
- At-speed test
- Timing design and delay test
- Summary

8 April 2008

2

Delay Test Definition

- A circuit that passes delay test must produce correct outputs when inputs are applied and outputs observed with specified timing.
- For a combinational or synchronous sequential circuit, delay test verifies the limits of delay in combinational logic.
- Delay test problem for asynchronous circuits is complex and not well understood.

8 April 2008

3

Digital Circuit Timing

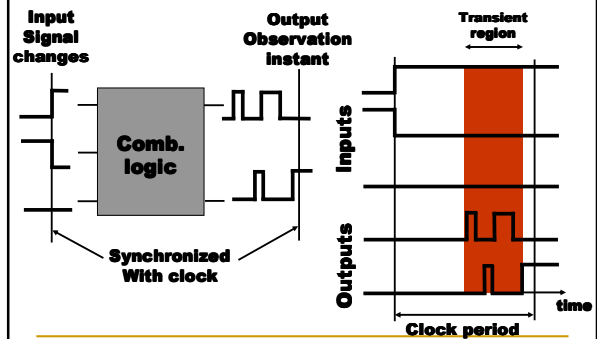

8 April 2008

4

Circuit Delays

- Switching or inertial delay is the interval between input change and output change of a gate:
 - Depends on input capacitance, device (transistor) characteristics and output capacitance of gate.
 - Also depends on input rise or fall times and states of other inputs (second-order effects).
 - Approximation: fixed rise and fall delays (or min-max delay range, or single fixed delay) for gate output.
- Propagation or interconnect delay is the time a transition takes to travel between gates:
 - Depends on transmission line effects (distributed R , L , C parameters, length and loading) of routing paths.
 - Approximation: modeled as lumped delays for gate inputs.
- See Section 5.3.5 for timing models.

8 April 2008

5

Event Propagation Delays

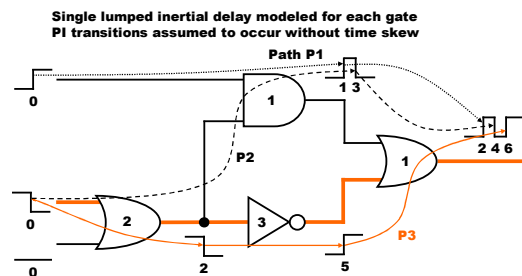

8 April 2008

6

Circuit Outputs

- Each path can potentially produce one signal transition at the output.
- The location of an output transition in time is determined by the delay of the path.

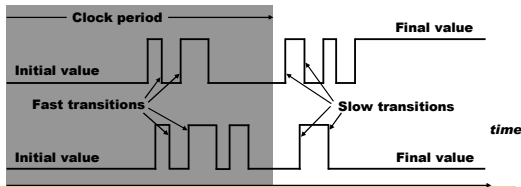

8 April 2008

7

Singly-Testable Paths (Non-Robust Test)

- The delay of a target path is tested if the test propagates a transition via path to a path destination.
- Delay test is a combinational vector-pair, $V1, V2$, that:
 - Produces a transition at path input.
 - Produces static sensitization -- All off-path inputs assume non-controlling states in $V2$.

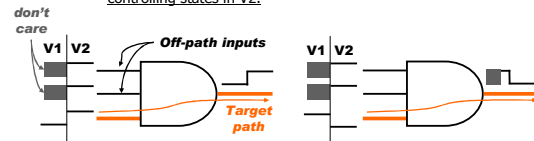

Static sensitization guarantees a test when the target path is the only faulty path. The test is, therefore, called *non-robust*. It is a test with minimal restriction. A path with no such test is a *false path*.

See Figure 12.4, page 422

8 April 2008

8

Robust Test

- A robust test guarantees the detection of a delay fault of the target path, irrespective of delay faults on other paths.
- A robust test is a combinational vector-pair, $V1, V2$, that satisfies following conditions:
 - Produce *real events* (different steady-state values for $V1$ and $V2$) on all on-path signals.
 - All on-path signals must have *controlling events* arriving via the target path.
- A robust test is also a non-robust test.
- Concept of robust test is general – robust tests for other fault models can be defined.

8 April 2008

9

Robust Test Conditions

- Real events on target path.
- Controlling events via target path.

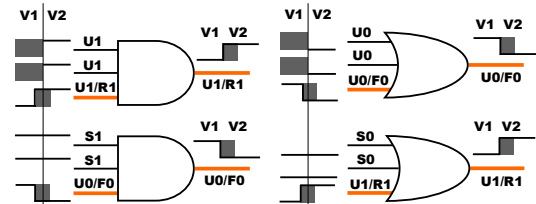

8 April 2008

10

A Five-Valued Algebra

- Signal States: $S0, U0$ ($F0$), $S1, U1$ ($R1$), XX .
- On-path signals: $F0$ and $R1$.
- Off-path signals: $F0=U0$ and $R1=U1$.

		Input 1						Input 2					
		S0	U0	S1	U1	XX	S0	U0	S1	U1	XX		
AND	Input 2	S0	S0	S0	S0	S0	S0	S0	S0	S0	S0		
	U0	S0	U0	U0	U0	U0	U0	U0	U0	U0	U0		
	S1	S0	U0	S1	U1	XX	S1	S1	S1	S1	S1		
	U1	S0	U0	U1	U1	XX	U1	U1	U1	U1	U1		
	XX	S0	U0	XX	XX	XX	XX	XX	XX	XX	XX		
		Input						Ref.:					
		S0	U0	S1	U1	XX	Lin-Reddy						
		S1	U1	S0	U0	XX	IEEETCAD-87						

8 April 2008

11

Robust Test Generation

Test for $\downarrow P3$ – falling transition through path $P3$: Steps A through E

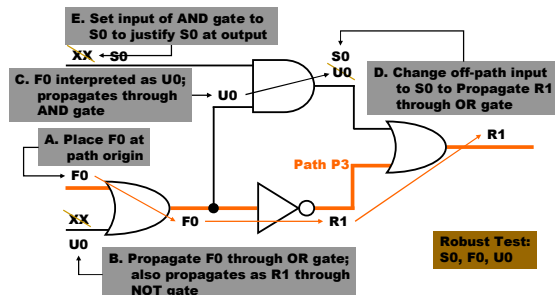

8 April 2008

12

Non-Robust Test Generation

Fault \uparrow P2 - rising transition through path P2 has no robust test.

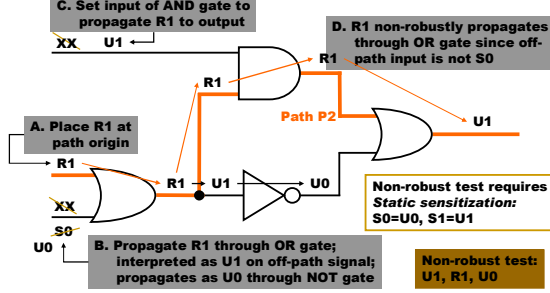

8 April 2008

15

Path-Delay Faults (PDF)

- Two PDFs (rising and falling transitions) for each physical path.
- Total number of paths is an exponential function of gates. Critical paths, identified by static timing analysis (e.g., *Primetime* from Synopsys), must be tested.
- PDF tests are delay-independent. Robust tests are preferred, but some paths have only non-robust tests.
- Three types of PDFs (Gharaybeh, et al., *JETTA* (11), 1997):
 - Singly-testable* PDF - has a non-robust or robust test.
 - Multiply-testable* PDF - a set of singly untestable faults that has a non-robust or robust test. Also known as functionally testable PDF.
 - Untestable* PDF - a PDF that is neither singly nor multiply testable.
- A singly-testable PDF has at least one *single-input change* (SIC) non-robust test.

8 April 2008

14

Other Delay Fault Models

- Segment-delay* fault -- A segment of an I/O path is assumed to have large delay such that all paths containing the segment become faulty.
- Transition* fault -- A segment-delay fault with segment of unit length (single gate):
 - Two faults per gate; slow-to-rise and slow-to-fall.
 - Tests are similar to stuck-at fault tests. For example, a line is initialized to 0 and then tested for s-a-0 fault to detect slow-to-rise transition fault.
 - Models spot (or gross) delay defects.
- Line-delay* fault -- A transition fault tested through the longest delay path. Two faults per line or gate. Tests are dependent on modeled delays of gates.
- Gate-delay* fault -- A gate is assumed to have a delay increase of certain amount (called *fault size*) while all other gates retain some nominal delays. Gate-delay faults only of certain sizes may be detectable.

8 April 2008

15

Slow-Clock Test

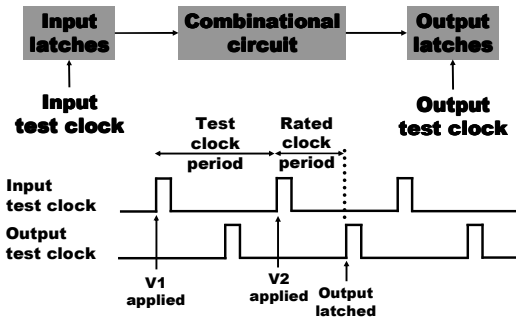

8 April 2008

16

Enhanced-Scan Test

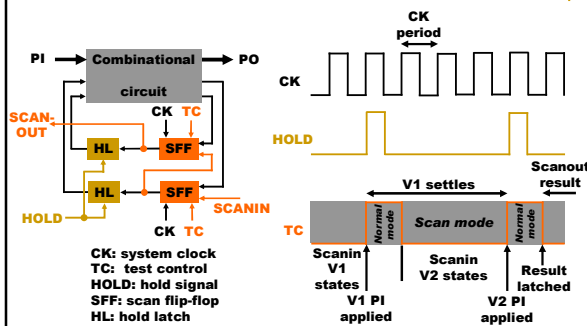

8 April 2008

17

Normal-Scan Test

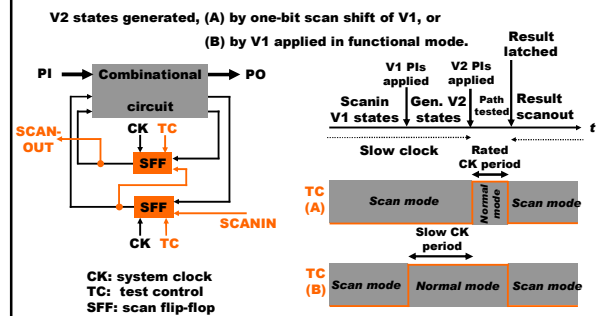

8 April 2008

18

Variable-Clock Sequential Test

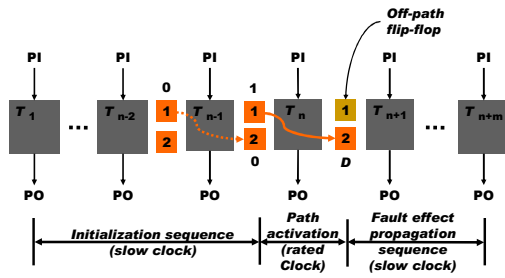

8 April 2008

19

Variable-Clock Models

- Fault effect propagation can be affected by ambiguous states of off-path flip-flops at the end of the rated-clock time-frame (Chakraborty, *et al.*, *IEEE TCAD*, Nov. 1997):
 - Fault model A – Off-path flip-flops assumed to be in correct states; *sequential non-robust test* (optimistic).
 - Fault model B – Off-path flip-flops assumed to be in unknown state; *sequential robust test* (pessimistic).
 - Fault model C – Off-path flip-flops in steady (hazard-free) state retain their correct values, while others assume unknown state; *sequential robust test*.
- Test length: A test sequence of N vectors is repeated N times, with a different vector applied at rated-clock each time.
 - Test time $\sim N^2 \times$ (slow-clock period)

8 April 2008

20

Variable-Clock Example

- ISCAS'89 benchmark s35932 (non-scan).
- 2,124 vectors obtained by simulator-selection from random vectors (Parodi, *et al.*, ITC-98).
- PDF coverage, 26,228/394,282 \sim 6.7%
- Longest tested PDF, 27 gates; longest path has 29 gates.
- Test time \sim 4,511,376 clocks.

8 April 2008

21

Rated-Clock Sequential Test

- All vectors are applied with rated-clock.
- Paths are singly and multiply activated potentially in several time-frames.
- Test generation requires a 41-valued logic (Bose, *et al.*, *IEEE TVLSI*, June 1998).
- Test generation is extremely complex for non-scan circuits (Bose and Agrawal, ATS-95).
- Fault simulators are effective but work with conservative assumptions (Bose, *et al.*, *IEEE TVLSI*, Dec. 1993; Parodi, *et al.*, ITC-98).

8 April 2008

22

Comparing PDF Test Modes

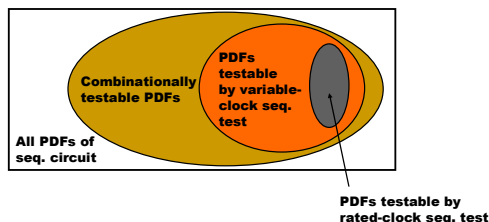

Ref.: Majumder, *et al.*, *VLSI Design - 98*

8 April 2008

23

At-Speed Test

- At-speed test means application of test vectors at the rated-clock speed.
- Two methods of at-speed test.
 - External test:
 - Vectors may test one or more functional critical (longest delay) paths and a large percentage (\sim 100%) of transition faults.
 - High-speed testers are expensive.
 - Built-in self-test (BIST):
 - Hardware-generated random vectors applied to combinational or sequential logic.
 - Only clock is externally supplied.
 - Non-functional paths that are longer than the functional critical path can be activated and cause a good circuit to fail.
- Some circuits have initialization problem.

8 April 2008

24

Timing Design & Delay Test

- Timing simulation:
 - Critical paths are identified by static (vector-less) timing analysis tools like *Primetime* (Synopsys).
 - Timing or circuit-level simulation using designer-generated functional vectors verifies the design.
- Layout optimization: Critical path data are used in placement and routing. Delay parameter extraction, timing simulation and layout are repeated for iterative improvement.
- Testing: Some form of at-speed test is necessary. PDFs for critical paths and all transition faults are tested.

8 April 2008

25

Summary

- *Path-delay fault* (PDF) models distributed delay defects. It verifies the timing performance of a manufactured circuit.
- *Transition fault* models spot delay defects and is testable by modified stuck-at fault tests.
- Variable-clock method can test delay faults but the test time can be long.
- Critical paths of non-scan sequential circuits can be effectively tested by rated-clock tests.
- Delay test methods (including BIST) for non-scan sequential circuits using slow ATE require investigation:
 - Suppression of non-functional path activation in BIST.
 - Difficulty of rated-clock PDF test generation.
 - Long sequences of variable-clock tests.

8 April 2008

26